

Sensor Based Efficient Security System

Md. Saidur Rahman¹, Sairatun Nesa Soheli²

¹Senior Lecturer of Computer Science and Engineering, IUBAT–International University of Business Agriculture and Technology, Uttara, Dhaka, Bangladesh.

²Lecturer of Electrical and Electronics Engineering, IUBAT–International University of Business Agriculture and Technology, Uttara, Dhaka, Bangladesh.

Abstract: This paper presents home office and industrial security system using sensor based surveillance camera which consumes less amount of electricity & memory. It also increases product lifetime and ensure better performance.

Index Item: Introduction, Methodology, Block Diagram, Circuit Description

I. Introduction

Surveillance cameras generally used in home, office and industrial areas are for security purposes. However it consumes lots of electricity and memory to keep the footage. Sometimes video footages are not that much clear to identify people due to low quality video for memory efficiency.

To reduce the drawbacks of this system we can use some sensors which will control the whole security system. Sensors include motion detection, thermal and sound detection. For any types of security occurrence, sensor will trigger the relay and activate video camera and generate security signals. When sensors will not get anything, a timer will activate to stop video camera and security signals.

II. Methodology

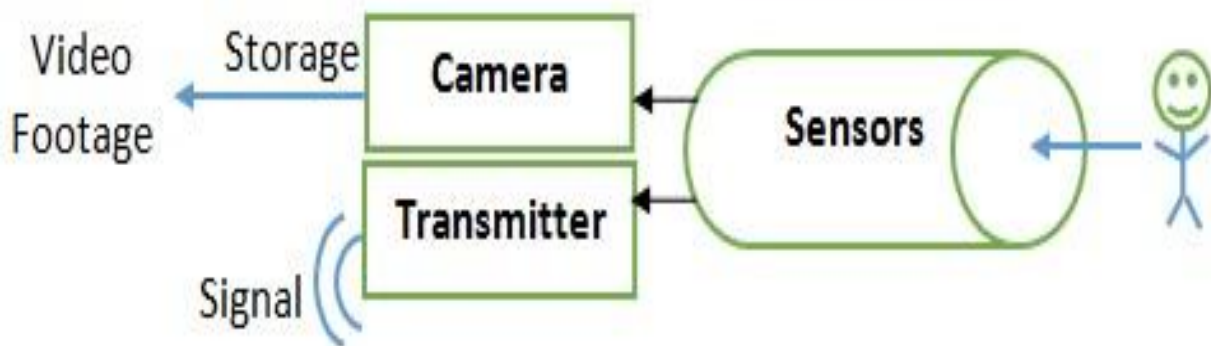

- ❖ If anything detect on sensors then Security system will enable.
- ❖ Transmitter will send signals to the control room and start record the video footage of the place of occurrence.
- ❖ Again the place will became silent and all movement will stop then timer will start to stop the recording and stop sending signals by turning relay off.

III. Block Diagram

The block diagram of Sensor Based Security System shown in below:

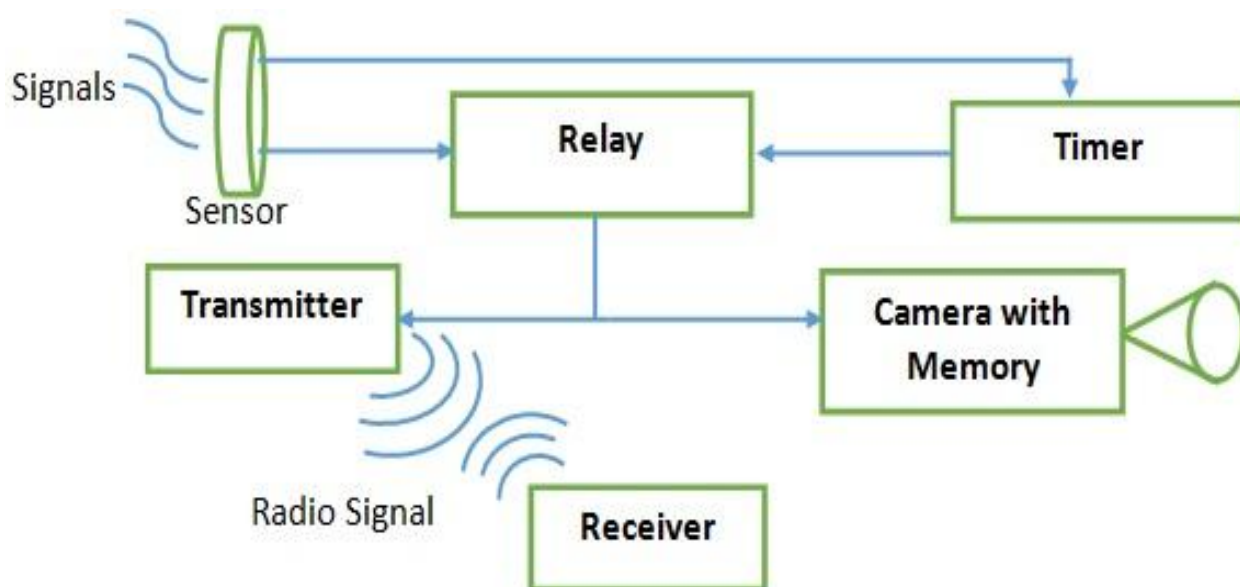

IV. Working Principle

When the sensor will detect any unwanted detection then it will activate relay and timer. Relay will activate the transmitter to send signal to security control room. It's a unique signal by which security people can identify the place of transmitter. At the same time relay also turn on security camera with high quality video footage.

V. Component Used

- ❖ 12V AC-DC Converter: It convert from 220V AC to 12V DC
- ❖ Sound Sensor: The Sound Sensor module is a simple microphone based power amplifier LM386 and the electrets microphone; it can be used to detect the sound strength of the environment. The value of output can be adjusted by the potentiometer.
- ❖ PIR Motion Sensor: The PIR Motion Sensor senses the motion of a human body by the change in surrounding ambient temperature when a human body passes across. Then it turns on the lighting load to which it is connected. The lighting load will remain 'ON' until it senses motion.
- ❖ Surveillance Camera: This is a water-resistance microSD memory card supported video camera C901 (Coomatec). It can recognize faces clearly in 25 meters. When relay turn on power, camera will start recording. Recorded video will capture and save in the microSD memory card in the camera.
- ❖ Relay: Relay receive signals from any sensors and turn on the power of camera and transmitter.
- ❖ Transceiver: Generate specific radio signals to the receiver where receiver will detect the specific transmitter connected with camera and relay
- ❖ Timer: Start adjustable countdown time when the input voltage is 0V. After the time, it will generate 12V DC to the other terminal of relay and turn off camera and transmitter.

VI. Circuit Operation

- ❖ A step down transformer which decrease voltage to 12 volt from 220 volt. Full wave rectifier will use to make DC voltage from AC and 6400 μ F capacitor to filter DC current.
- ❖ Sound Sensor and PIR Motion Sensor switch generate 12V DC to relay and timer.
- ❖ Relay turns on mains of the camera and transmitter.
- ❖ Transmitter generates specific signals to the receiver.
- ❖ Camera will start recording and recorded footage save into microSD memory card.
- ❖ When the input voltage is 0V, timer will start and after countdown time it generates 12V DC to another terminal of relay and relay will turn off camera and transmitter.
- ❖ Receiver receives signals from transmitter and detect from which transmitter it comes from.

VII. Conclusion

This security system works precisely with the help of multiple sensors. This sensor based security system can be used for any home, organization, company and industry for security reasons. Different sensors jointly make the security much stronger both day and night time. Relay and timer will prevent unnecessary use of electricity, camera and memory. To use this system it is possible to save electricity bill and also can increase the lifetime of devices.

VIII. Future Scope

- ❖ Currently audio facility is not available. The system will be improved the facility to both audio and video in near future.
- ❖ Video transmitter will be added so that it can be monitor lively from security control room.

IX. Acknowledgement

This work was supported by IUBAT–International University of Business Agriculture and Technology

References

- [1]. <http://www.cctvcamerapros.com/security-camera-systems-s21.htm>
- [2]. <http://www.cctvcamerapros.com/Motion-Detector-Surveillance-Camera-p/pir-600dn.htm>
- [3]. <http://www.tenbestreview.com/electronics-gadgets/top-10-best-wireless-security-cameras-in-2015/>
- [4]. <https://www.sparkfun.com/products/12642>
- [5]. <https://lowvoltage.wordpress.com/2011/05/15/lm386-mic-amp/>
- [6]. <https://www.sparkfun.com/products/13285>
- [7]. <https://www.adafruit.com/products/189>
- [8]. <http://www.instructables.com/id/Getting-Started-With-Relays/>
- [9]. <http://www.ebay.com/itm/Timer-Relay-Switch-1-300-second-5V-9V-12v-DC-input-TIME-OVER-RESET-Delay-/261409488357>
- [10]. <https://books.google.com.bd/books?isbn=0080468187>
- [11]. <http://sine.ni.com/nips/cds/viewp/lang/en/nid/210629>
- [12]. http://www.lightinthebox.com/coomatec-dvrcam-cctv-sd-card-dvr-ir-cut-waterproof-camera-c901-lens-8mm-array-led_p776872.html